



Parts Manual

Models

521 SSE (621502X37NA)

521 SSR (621503X37NA)

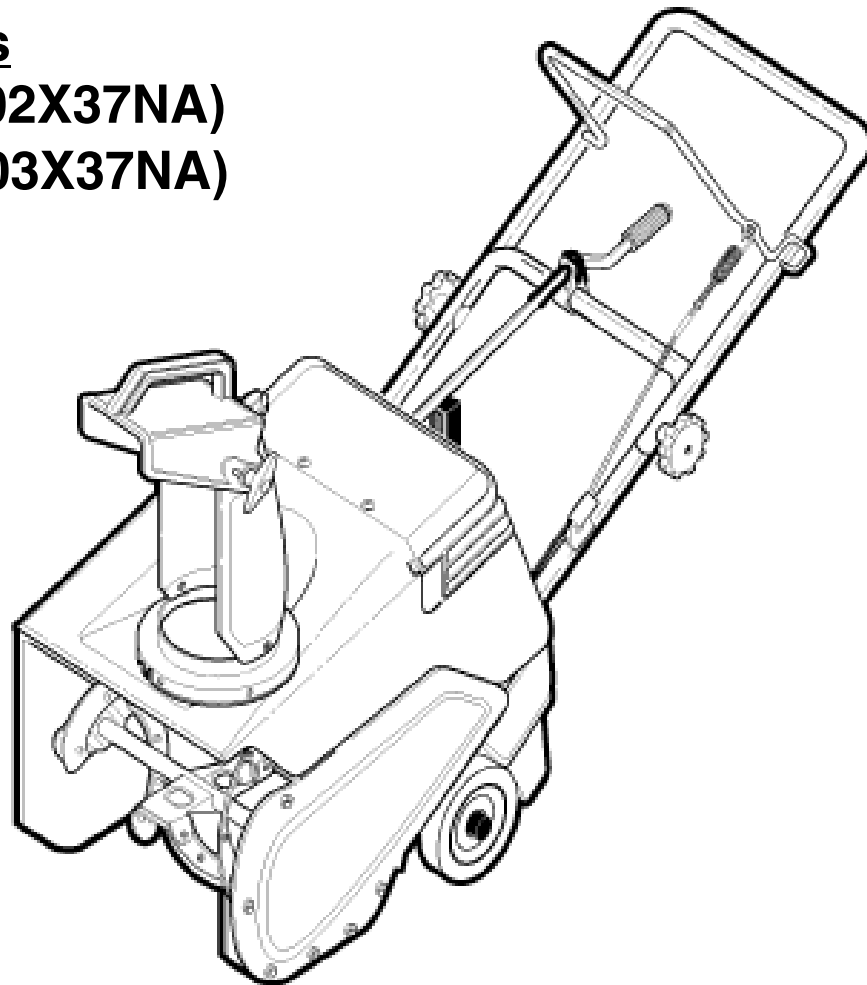

Handle Group

0007

NOTE: Unless noted otherwise,
use the standard hardware torque
specification chart.

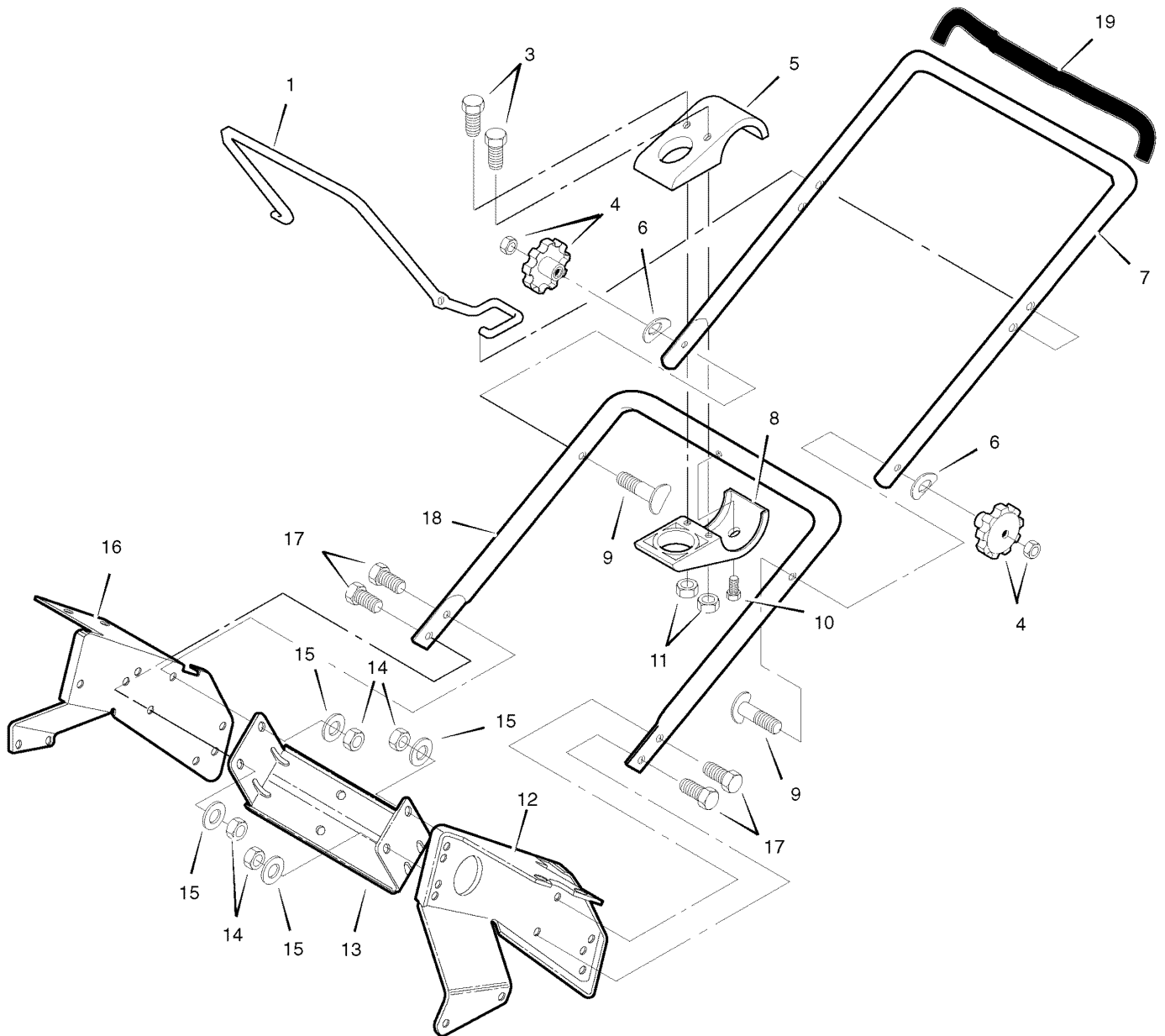

The above parts group applies to the following Mfg. Nos.:

621502x37NA 521SSE
621503x37NA 521SSR

Handle Group

REF NO	PART NO.	DESCRIPTION
1	601 40 00 28	DRIVEBAR
3	601 00 18 26	SCREW 10-24 x 1.00
4	601 40 00 55	KNOB
5	601 00 18 24	BRACKET, UPPER CRANK
6	601 00 24 13	WASHER, FORMED
7	601 40 00 47	HANDLE, UPPER w/FOAM
8	601 00 18 25	BRACKET, LOWER CRANK
9	601 00 21 50	BOLT, FORMED HEAD
10	601 00 14 45	SCREW .25-20 x .62
11	601 40 00 78	NUT, LOCK 10-24
12	601 40 00 23	PLATE, REAR MOUNT LH
13	601 40 00 21	FRAME SUPPORT
14	601 40 00 85	NUT, LOCK .31-18
15	601 40 00 79	WASHER, LOCK
16	601 40 00 22	PLATE, REAR MOUNT RH
17	601 40 00 43	SCREW .31-18 x .75
18	601 40 00 35	LOWER HANDLE
19	601 40 00 18	TUBING, FOAM

Footnotes

The above parts group applies to the following Mfg. Nos.:

621502x37NA 521SSE

621503x37NA 521SSR

Engine Group

NOTE: Unless noted otherwise,
use the standard hardware torque
specification chart.

0003

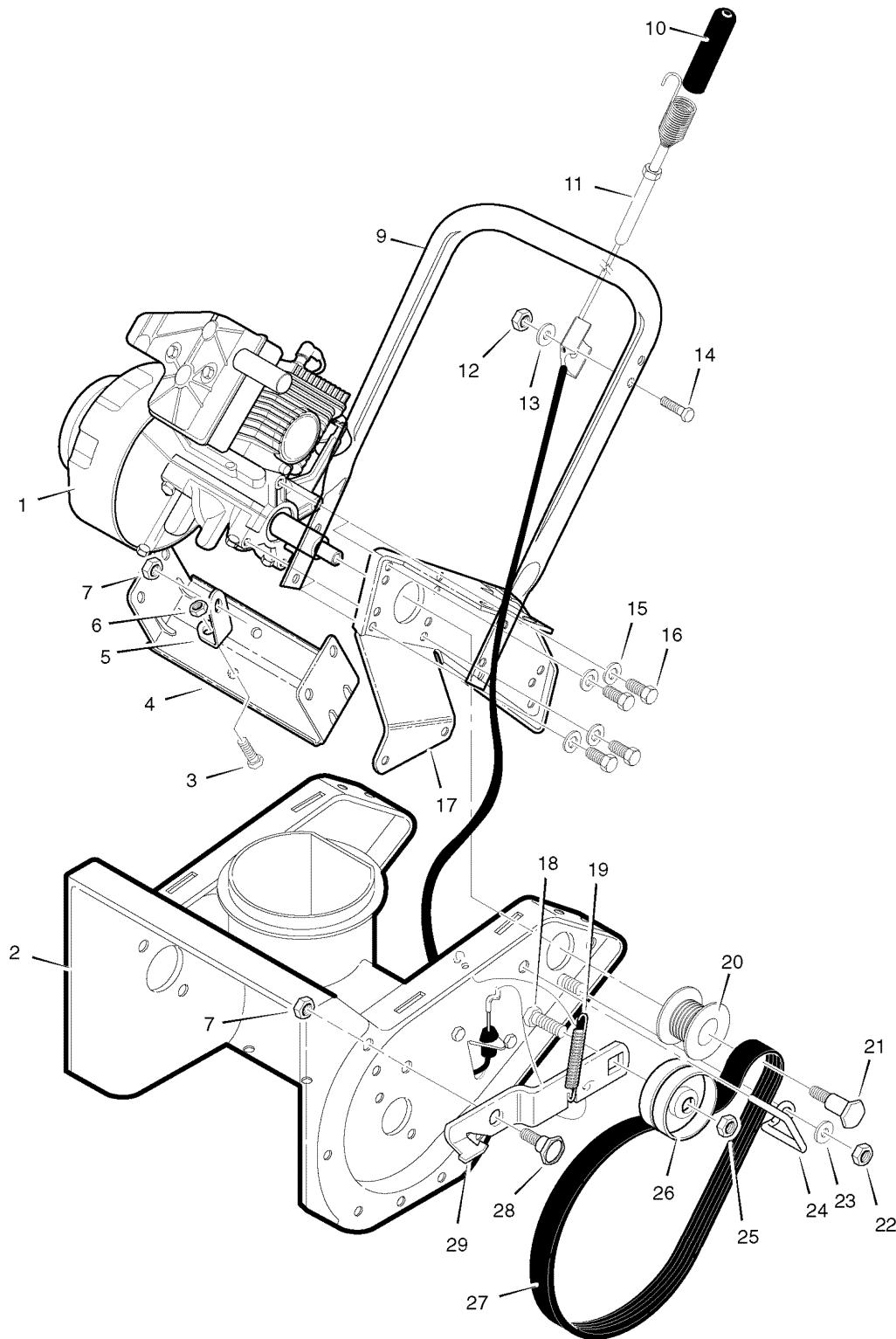

The above parts group applies to the following Mfg. Nos.:

621502x37NA 521SSE

621503x37NA 521SSR

Engine Group

REF NO	PART NO.	DESCRIPTION
1	----	ENGINE
2	601 40 00 58	AUGER HOUSING, 21"
3	601 40 00 46	SCREW, .31-18 x .5
4	601 40 00 21	SUPPORT, FRAME
5	601 40 00 20	SUPPORT, ENGINE
6	601 40 00 85	NUT.31-18 HEX
7	601 40 00 85	NUT .31-18 HEX
9	601 40 00 35	HANDLE, LOWER
10	601 00 17 59	COVER, CABLE SPRING
11	601 40 00 51	CABLE, DRIVE
12	601 40 00 86	LOCKNUT .25-20 HEX
13	601 40 00 80	WASHER .286-0.62-.07
14	601 00 17 58	SCREW .25-20 x 1.50
15	601 40 00 79	WASHER .318-0.56-.05
16	601 40 00 43	SCREW, .31-18 x .63
17	601 40 00 23	PLATE, REAR
18	601 00 05 51	BOLT, CARRIAGE .38-16 x 1.50
19	601 00 20 60	SPRING, IDLER BRAKE
20	601 40 00 05	PULLEY, 4.5 HP
21	601 00 20 80	BOLT, SHOULDER .625 x .280
22	601 40 00 85	NUT.31-18 HEX
23	601 40 00 01	WASHER, FLAT .312 x .73 x .065
24	601 40 00 59	GUIDE, BELT
25	601 40 00 75	JAM NUT.38-16 HEX
26	601 00 13 33	PULLEY, IDLER
27	601 40 00 62	BELT, POLY-V 10 RIB 35.14
28	601 00 13 29	BOLT, SHOULDER
29	601 40 00 57	BRACKET, IDLER ARM
--	601 40 00 00	OWNER'S MANUAL (Not Illustrated)

Footnotes

The above parts group applies to the following Mfg. Nos.:

621502x37NA 521SSE

621503x37NA 521SSR

Frame Group

0005

NOTE: Unless noted otherwise,
use the standard hardware torque
specification chart.

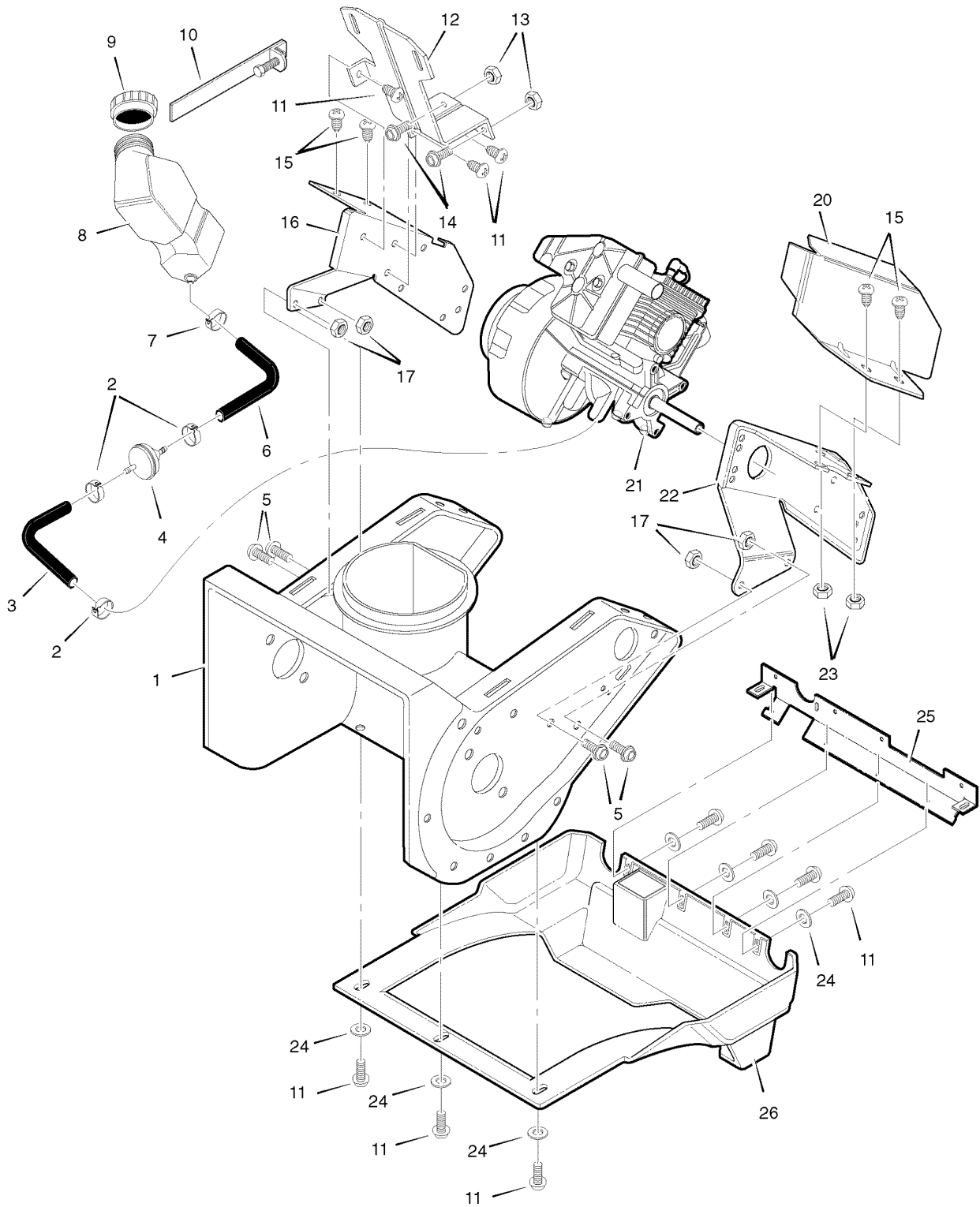

The above parts group applies to the following Mfg. Nos.:

- 621502x37NA 521SSE
- 621503x37NA 521SSR

Frame Group

REF NO	PART NO.	DESCRIPTION
1	601 40 00 58	AUGER HOUSING 21"
2	601 00 17 79	CLAMP, TUBING
3	601 40 00 54	TUBING, FUEL
4	601 40 00 63	FILTER, FUEL
5	601 40 00 46	SCREW .31-18 x .50
6	601 00 17 76	TUBING, FUEL
7	601 40 00 65	CLAMP, TUBING
8	601 00 17 74	FUEL TANK
9	601 00 17 75	CAP, FUEL
10	601 40 00 37	CLAMP, WORM DR
11	601 40 00 34	SCREW 10-24 x .62
12	601 40 00 32	BRACKET, FUEL TANK
13	601 00 13 67	NUT, LOCK 10-24
14	601 40 00 17	SCREW 10-24 x .50
15	601 40 00 52	SCREW .25-20 x .62
16	601 40 00 22	PLATE, REAR MT RH
17	601 40 00 85	NUT, LOCK .31-18
20	601 40 00 38	HEAT SHIELD
21	----	ENGINE
22	601 40 00 23	PLATE, REAR MT LH
23	601 40 00 26	NUT, LOCK .25-20
24	601 00 17 03	WASHER, FLAT
25	601 40 00 31	BRACKET, COVER
26	601 40 00 09	BOTTOM COVER Used on Model 521SSE (621502x37NA) Only
26	601 40 00 13	BOTTOM COVER Used on Model 521SSR (621503x37NA) Only

Footnotes

The above parts group applies to the following Mfg. Nos.:

621502x37NA 521SSE
621503x37NA 521SSR

Auger Housing Group

0009

NOTE: Unless noted otherwise,
use the standard hardware torque
specification chart.

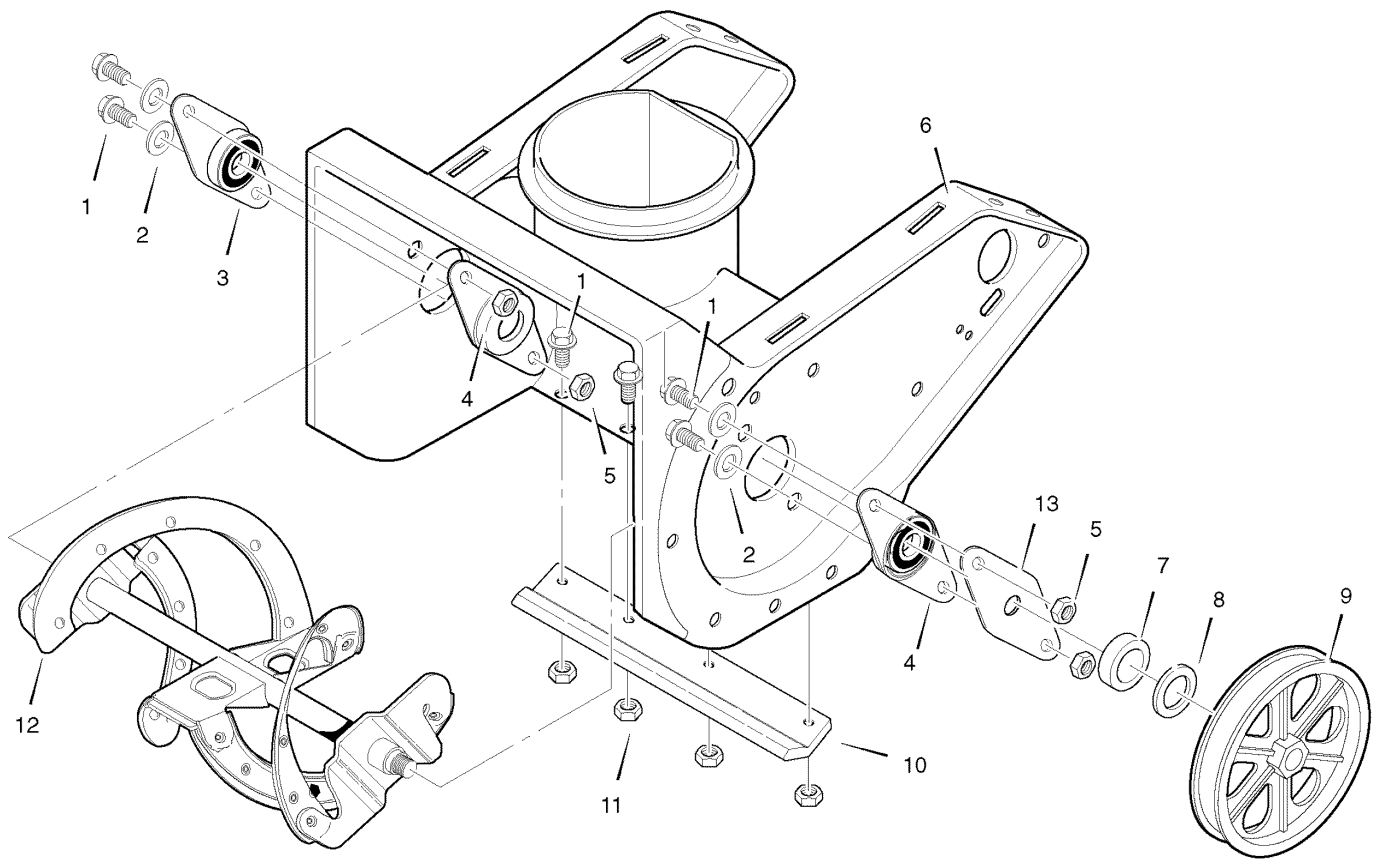

The above parts group applies to the following Mfg. Nos.:

621502x37NA 521SSE

621503x37NA 521SSR

Auger Housing Group

REF NO	PART NO.	DESCRIPTION
1	601 40 00 73	SCREW .25-20 x .63
2	601 40 00 80	WASHER, FLAT .281 x .63 x .065
3	601 40 00 68	PLATE, BEARING RETAINER
4	601 40 00 74	PLATE & BEARING ASSY
5	601 40 00 86	NUT, LOCK .25-20
6	601 40 00 58	AUGER HOUSING 21"
7	601 00 20 87	SPACER, SLEEVE
8	601 40 00 64	WASHER, FLAT .640 x 1.25 x .06
9	601 00 20 95	PULLEY, POLY V
10	601 00 17 96	SCRAPER BLADE
11	601 40 00 26	NUT, LOCK .25-20
12	601 40 00 53	AUGER ASSY
13	601 00 13 81	RETAINER BEARING

Footnotes

The above parts group applies to the following Mfg. Nos.:

621502x37NA 521SSE

621503x37NA 521SSR

Discharge Chute Group

0011

NOTE: Unless noted otherwise,
use the standard hardware torque
specification chart.

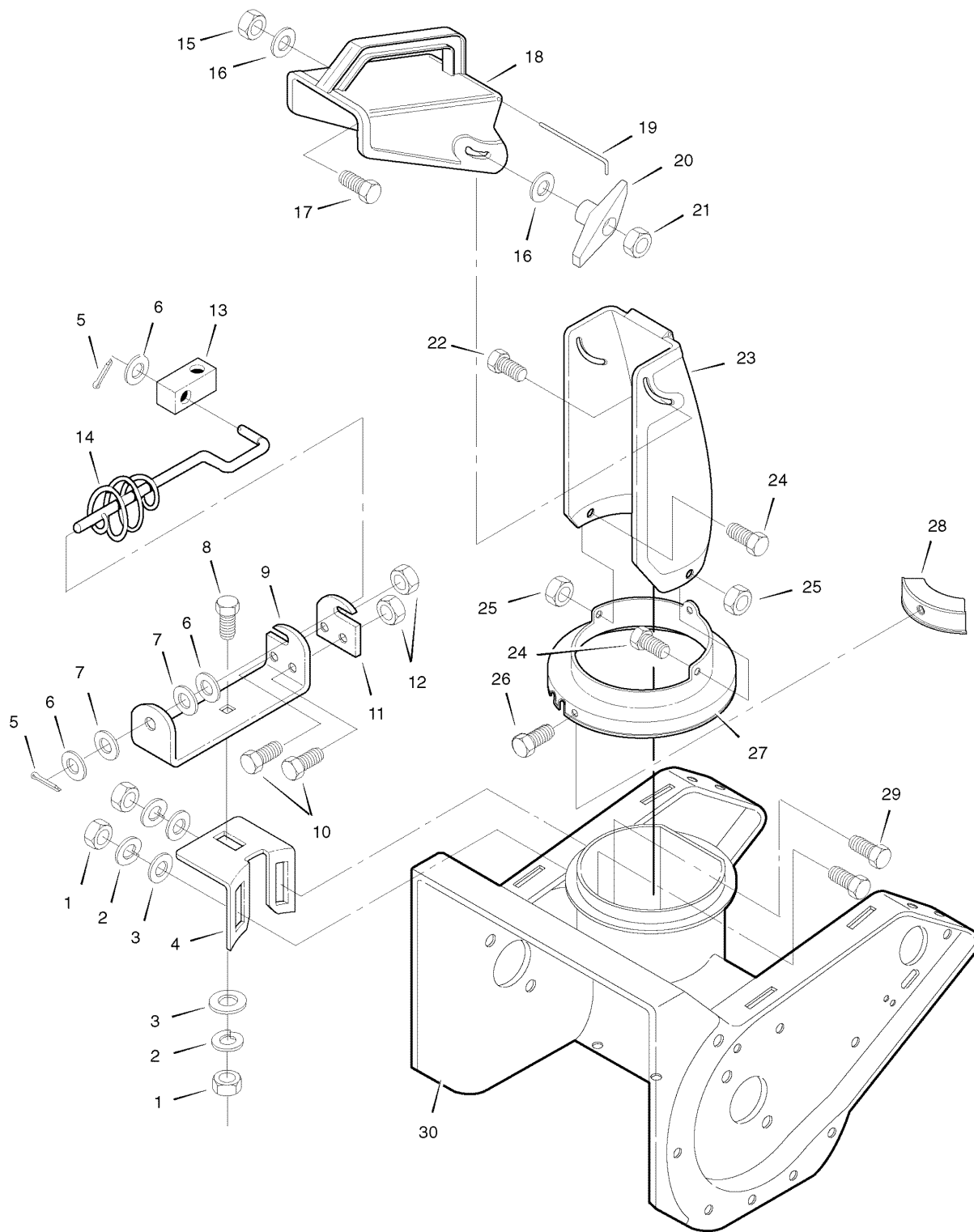

The above parts group applies to the following Mfg. Nos.:

621502x37NA 521SSE

621503x37NA 521SSR

Discharge Chute Group

REF NO	PART NO.	DESCRIPTION
1	601 40 00 07	NUT, .31-18 HEX
2	601 40 00 79	WASHER, LOCK
3	601 40 00 81	WASHER, FLAT .349-0.69-.07
4	601 40 00 25	BRKT, WORM ADJUST
5	601 40 00 83	PIN, COTTER.094x0.75L
6	601 40 00 03	WASHER, FLAT .400-0.75-.02
7	601 00 14 04	WASHER, SPRING .395-0.73-.01
8	601 00 14 11	BOLT, CARRIAGE .31-18x0.75
9	601 40 00 19	BRACKET, CHUTE ROD HOLE
10	601 40 00 45	SCREW, .25-20 x 0.50 Hex Head Cap
11	601 40 00 27	PLATE, CHUTE ROD
12	601 40 00 86	NUT, LOCK .25-20 Hex
13	601 00 18 11	BLOCK, PIVOT CHUTE
14	601 00 18 10	ROD ASSEMBLY, LOWER CHUTE
15	601 40 00 85	NUT, LOCK .31-18 HEX
16	601 40 00 81	WASHER, FLAT .349-0.69-.07
17	601 00 20 38	SCREW, .31-18 x 0.75
18	601 40 00 49	CHUTE, UPPER
19	601 00 13 89	WIRE FORM, HINGE
20	601 40 00 69	WINGKNOB
21	601 40 00 07	NUT, .31-18 HEX
22	601 00 13 90	BOLT, CARRIAGE .31-18 x 1.50
23	601 40 00 50	CHUTE, LOWER
24	601 40 00 45	SCREW, .25-20 x 0.50
25	601 40 00 86	NUT, LOCK .25-20
26	601 00 18 02	SCREW, .25-14 x 0.62
27	601 40 00 08	CHUTE RING
28	601 00 18 03	CLIP, CHUTE RING
29	601 00 14 11	BOLT, CARRIAGE .31-18 x 0.75
30	601 40 00 58	AUGER HOUSING, 21"

Footnotes

The above parts group applies to the following Mfg. Nos.:

621502x37NA 521SSE

621503x37NA 521SSR

Chute Rod Group

NOTE: Unless noted otherwise,
use the standard hardware torque
specification chart.

0017

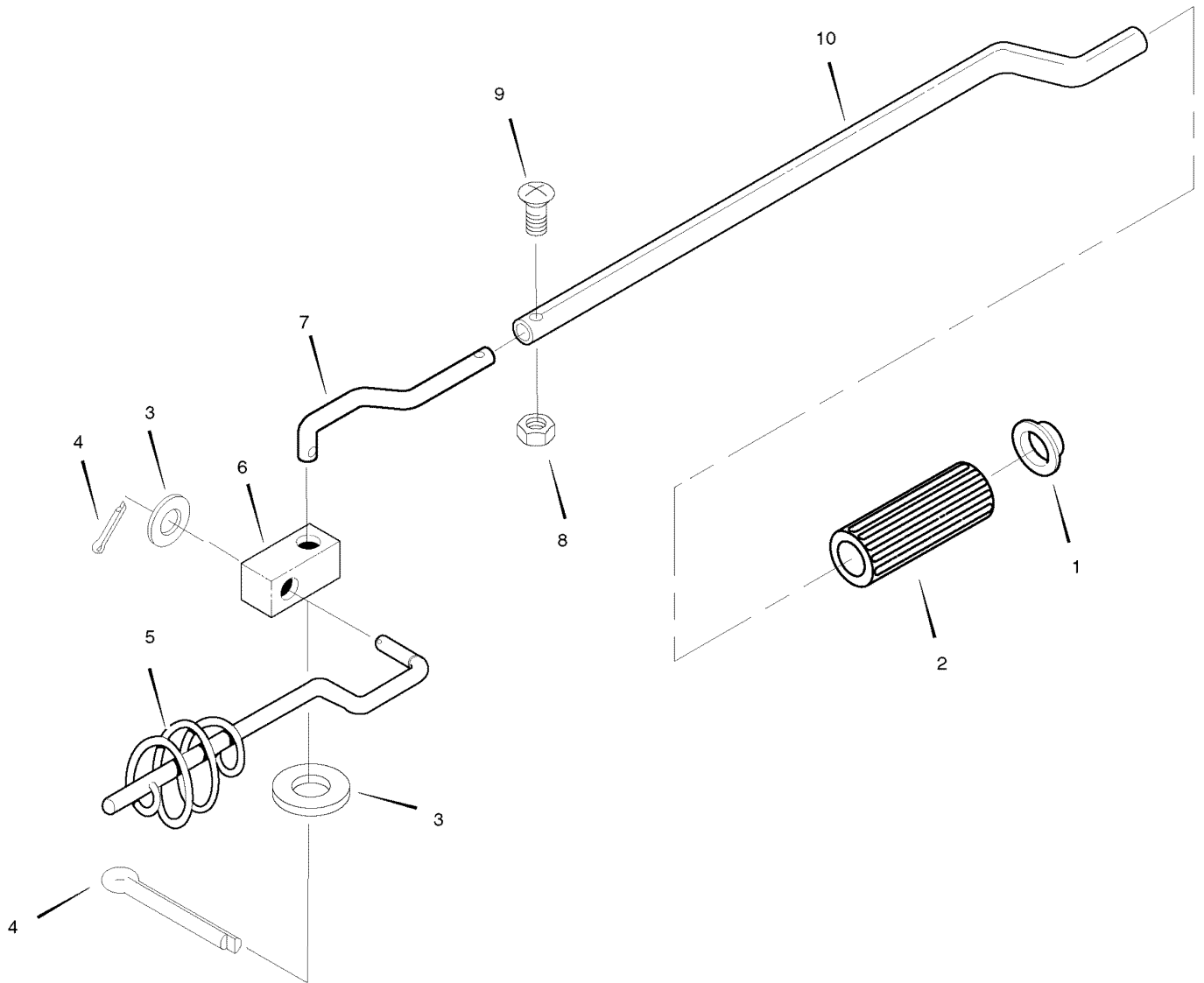

The above parts group applies to the following Mfg. Nos.:

621502x37NA 521SSE

621503x37NA 521SSR

Chute Rod Group

REF NO	PART NO.	DESCRIPTION
1	601 00 18 17	PUSH NUT
2	601 40 00 29	KNOB, GRIP
3	601 40 00 03	WASHER, FLAT .400 x .75 x .02
4	601 40 00 83	PIN, COTTER
5	601 00 18 10	ROD, CHUTE CNTRL LWR
6	601 00 18 11	BLOCK, PIVOT
7	601 40 00 30	ROD, CHUTE CNTRL MID
8	601 00 18 15	NUT, LOCK 10-32
9	601 40 00 48	SCREW, 10-32 x .88
10	601 40 00 33	ROD, CHUTE UPPER

Footnotes

The above parts group applies to the following Mfg. Nos.:

621502x37NA 521SSE

621503x37NA 521SSR

Decals Group

NOTE: Unless noted otherwise,
use the standard hardware torque
specification chart.

0019

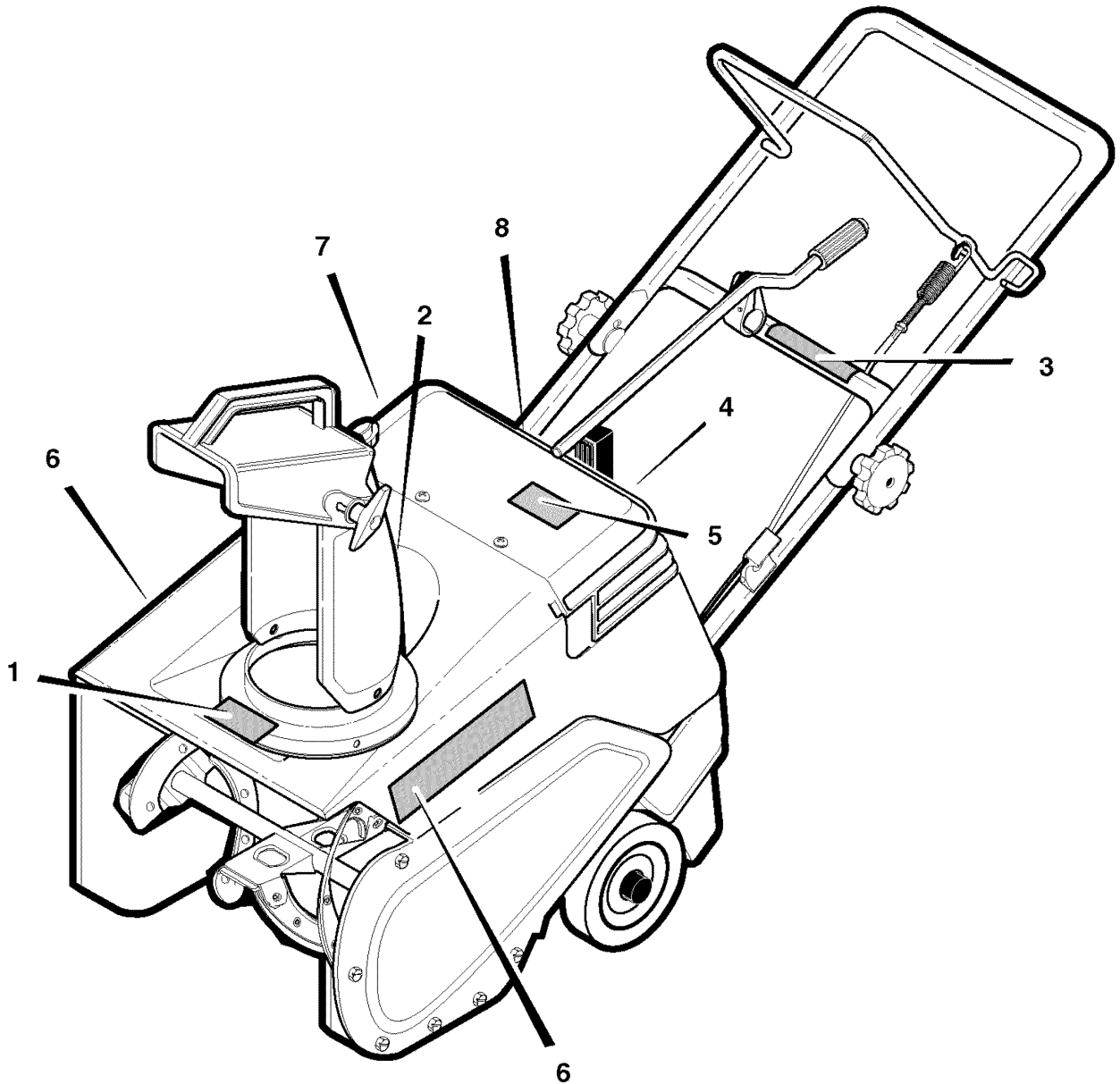

The above parts group applies to the following Mfg. Nos.:

621502x37NA 521SSE

621503x37NA 521SSR

Decals Group

REF NO	PART NO.	DESCRIPTION
1	601 40 00 66	DECAL, DANGER AUGER
2	601 40 00 67	DECAL, DANGER CHUTE
3	601 00 21 15	DECAL, AUGER CONTROL
4	601 40 00 61	DECAL, CONTROL PANEL Used on Model 521SSE (621502x37NA) Only
4	601 40 00 60	DECAL, CONTROL PANEL Used on Model 521SSR (621503x37NA) Only
5	601 40 00 77	DECAL, HOT MUFFLER
6	601 40 00 11	DECAL, Husqvarna 5/21
7	-----	DECAL, EPA
8	601 40 00 15	DECAL, 521SSE Used on Model 521SSE (621502x37NA) Only
8	601 40 00 16	DECAL, 521SSR Used on Model 521SSR (621503x37NA) Only
--	601 40 00 00	OPERATOR'S MANUAL (Not Illustrated)

Footnotes

Note* Not a serviceable part.

The above parts group applies to the following Mfg. Nos.:

621502x37NA 521SSE
621503x37NA 521SSR

Wheel Group

0015

NOTE: Unless noted otherwise,
use the standard hardware torque
specification chart.

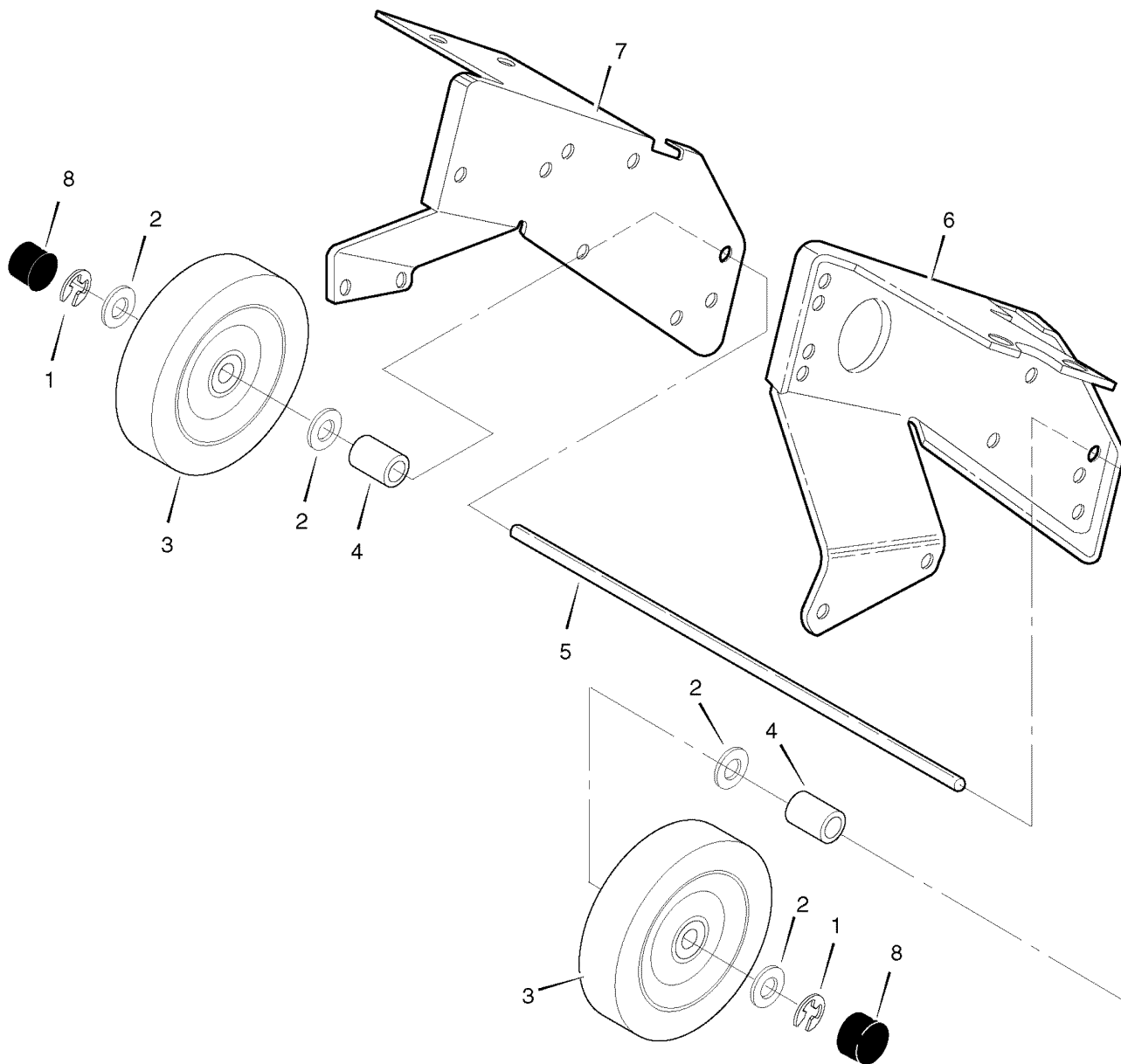

The above parts group applies to the following Mfg. Nos.:

621502x37NA 521SSE

621503x37NA 521SSR

Wheel Group

REF NO	PART NO.	DESCRIPTION
1	601 40 00 72	RING, RET. E
2	601 40 00 82	WASHER, FLAT .406 x .81 x .07
3	601 40 00 04	WHEEL, 7.75" x 1.75"
4	601 00 18 19	SPACER, SLEEVE
5	601 00 18 18	AXLE SHAFT
6	601 40 00 23	PLATE, REAR MOUNT LH
7	601 40 00 22	PLATE, REAR MOUNT RH
8	601 40 00 71	CAP, HUB

Footnotes

The above parts group applies to the following Mfg. Nos.:

621502x37NA 521SSE

621503x37NA 521SSR

Electric Starter Group

0021

NOTE: Unless noted otherwise,
use the standard hardware torque
specification chart.

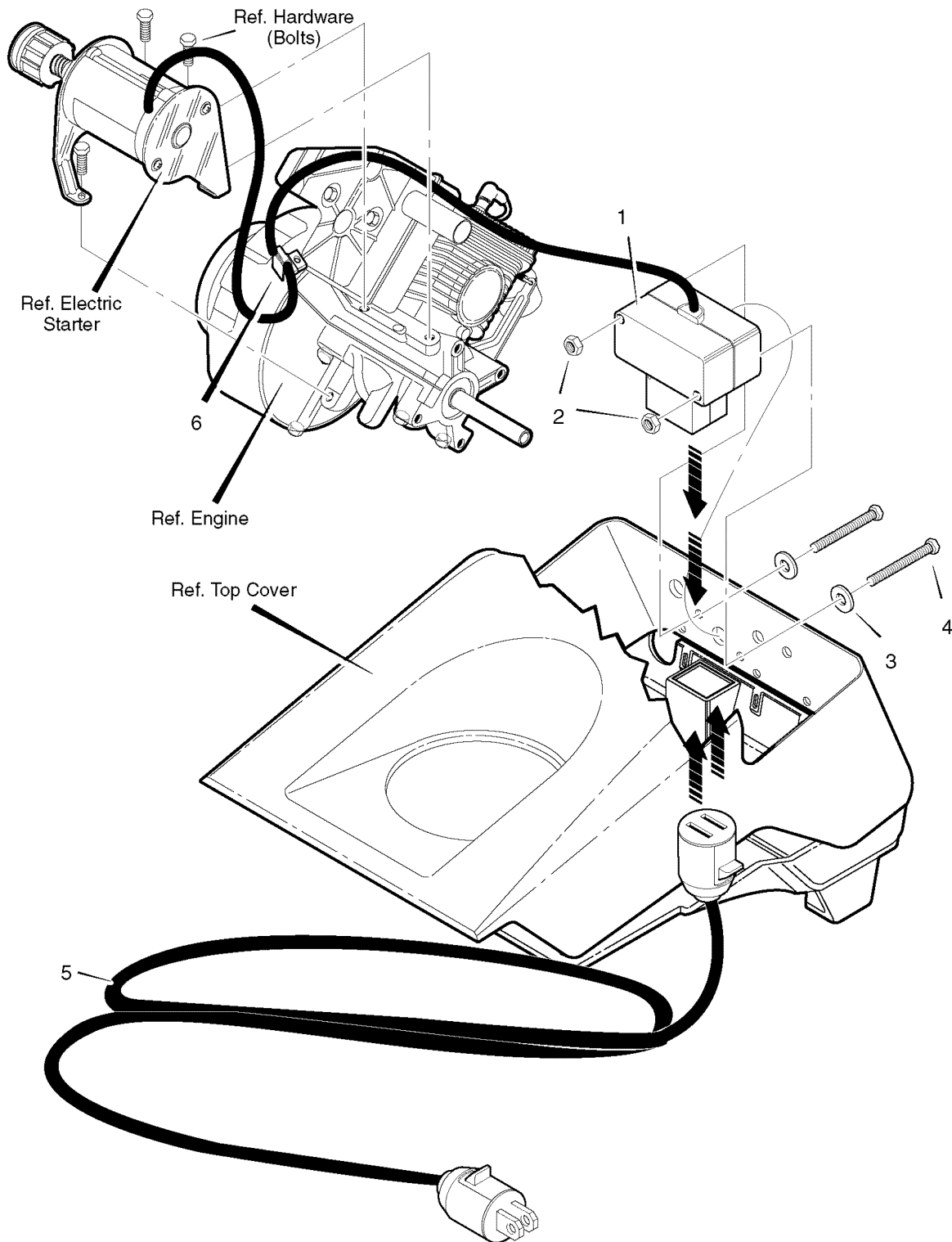

The above parts group applies to the following Mfg. Nos.:

621502x37NA 521SSE

Electric Starter Group

REF NO	PART NO.	DESCRIPTION
1	-----	ELECTRIC STARTER, INCLUDED WITH ENGINE Used on Model 521SSE (621502x37NA) Only
2	601 00 14 19	NUT, KEPS 8-32 Used on Model 521SSE (621502x37NA) Only
3	601 00 05 33	WASHER, FLAT Used on Model 521SSE (621502x37NA) Only
4	601 00 14 18	SCREW 8-32 x 3.00 Used on Model 521SSE (621502x37NA) Only
5	601 00 14 20	CORD, EXTENSION Used on Model 521SSE (621502x37NA) Only
6	601 40 00 06	STARTER CORD RETAINER Used on Model 521SSE (621502x37NA) Only

Footnotes

The above parts group applies to the following Mfg. Nos.:

621502x37NA 521SSE

Top Cover Group

0013

NOTE: Unless noted otherwise,
use the standard hardware torque
specification chart.

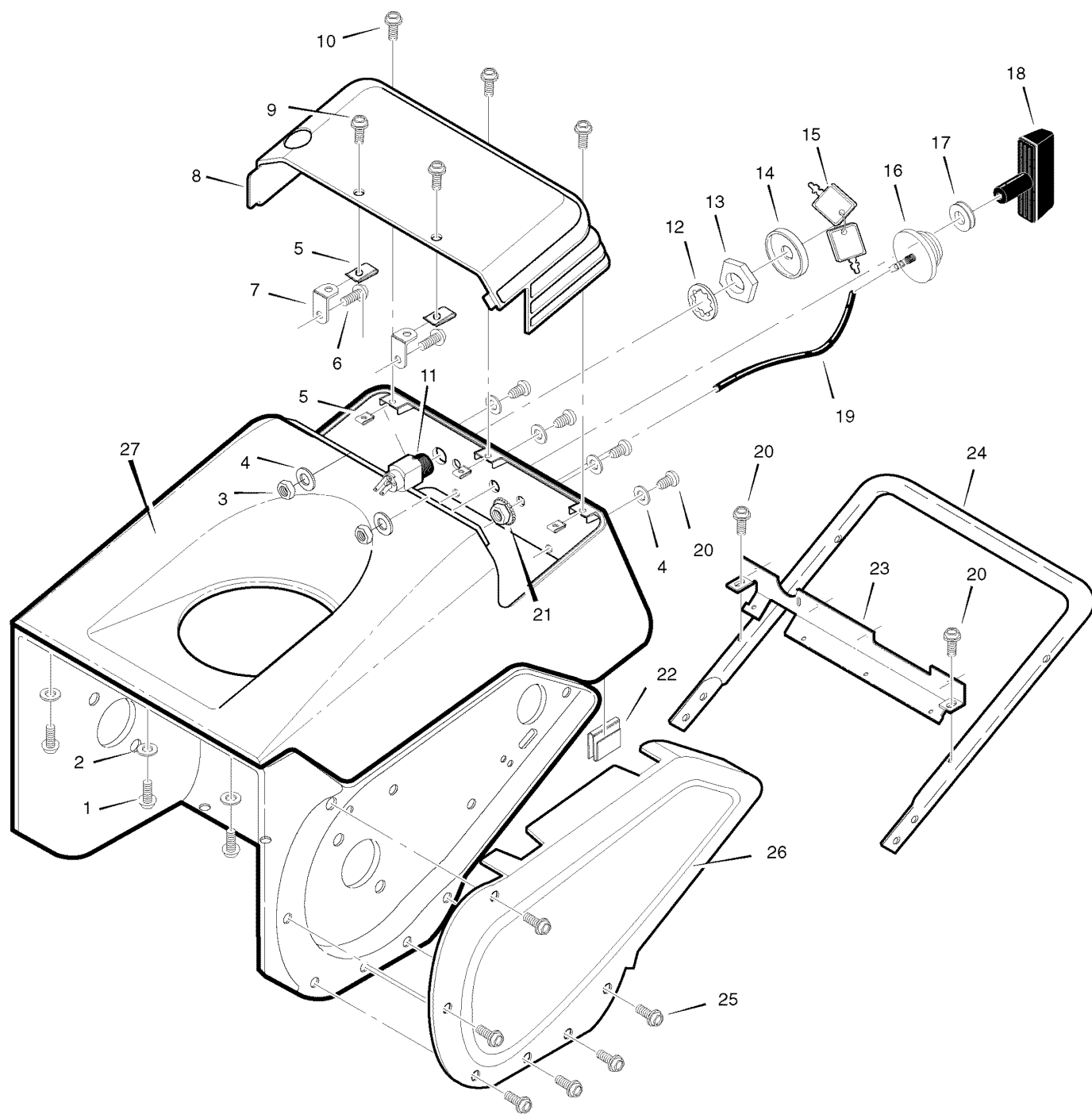

The above parts group applies to the following Mfg. Nos.:

621502x37NA 521SSE

621503x37NA 521SSR

Top Cover Group

REF NO	PART NO.	DESCRIPTION
1	601 00 17 87	SCREW 10-14 x .63
2	601 40 00 84	WASHER, FLAT
3	601 40 00 78	NUT, LOCK 10-24
4	601 00 17 03	WASHER, FLAT
5	601 00 17 88	NUT, U TYPE
6	601 40 00 02	SCREW 10-24 x .50
7	601 40 00 40	BRACKET, ACCESS COVER
8	601 40 00 12	COVER, ENGINE ACCESS
9	601 40 00 39	SCREW 10-16 x .62
10	601 40 00 41	SCREW 10-16 x .75
11	601 00 13 58	IGNITION SWITCH
12	601 40 00 44	WASHER, INTERNAL LOCK
13	601 00 01 11	NUT, .62-32 PLASTIC
14	601 00 01 12	BOOT, SWITCH
15	601 40 00 76	KEYS & RING
16	601 00 13 62	PRIMER BULB
17	601 40 00 70	GROMMET & WASHER
18	601 40 00 56	KNOB, STANDARD T
19	601 00 13 63	HOSE, PRIMER
20	601 40 00 34	SCREW 10-24 x .63
21	601 00 17 90	NUT .25-20 KEPS
22	601 40 00 42	CLIP, S
23	601 40 00 31	BRACKET, SHROUD MTG
24	601 40 00 35	LOWER HANDLE
25	601 40 00 36	SCREW 10-24 x .38
26	601 40 00 24	COVER, BELT
27	601 40 00 10	COVER, TOP

Footnotes

The above parts group applies to the following Mfg. Nos.:

621502x37NA 521SSE
621503x37NA 521SSR